

# Customer Notification

B-CN-080-EN Rev A

11/29/2017

**SUBJECT:** Hardware Changes on TT and TG Series Compressors – Phase II

## Purpose

This bulletin is to notify all customers that the hardware (screws/bolts/washers) used on TT and TG series compressors is being updated for new compressor models manufactured beginning January 2018. The rollout for all compressor models could vary slightly due to current inventory levels.

The hardware is being changed because, in some environmental conditions, corrosion can form on the hardware which gives a negative impression of product quality. In general, there is no functional impact as a result of the corrosion but there is an impact on the aesthetics.

**All new Turbocor compressor models and affected Spare Part Kits have been updated to use Stainless Steel in all areas.** The first phase of this effort was completed in February 2017. Phase II is involved with updating all of the remaining fasteners.

**Phase II** – Consists of changing all external hardware and hardware which has the potential to be exposed to condensation or external environmental conditions. Phase II necessitated a change to some of the hardware used in the following kits:

- Module Backplane Assembly (100021-1)
- Soft Start (100020-1, 2, 3, 4, 6, 7)
- Diode Rectifiers (100047-1, 2)
- Ground Stud (100519)
- Mounting (100066)
- Input Mains Bus Bars (100416)
- DC-DC Converter Assembly (100040-3, 5, 6)
- 613 Inverter Assembly (100043-7, 11, 12)
- Module PWM Bearing (100022, 100372)
- Hermetic Feedthrough High Power (100312, 100312-1)
- Bus Assembly Connection Motor Inverter (100313, 100313-1)
- IGV Housing (100223, 100224, 100229)
- Diode Rectifiers (100047-2)
- Heatsink Cooling Manifold SCR Assembly (100309-5, 6)
- Capacitor Cover Assembly (100053-3, 4, 6)
- Top Cover Assembly (100054-3, 4, 6, 7, 8)
- Service Side Cover (100055-7, 8, 9)
- Mains Input Cover Assembly (100056-3, 4, 6, 7, 8)
- Capacitor, Inverter, IGBT Snubber (100417)
- Bus Bar Diode (100316)
- Tube Connection to Inverter (100311)
- Cooling Fan Assembly (100234)
- Bracket Mains Input Plate 2.0" Diameter (100216)
- Bracket Mains Input Plate 2.5" Diameter (100217)
- Bracket Mains Input Plate 3.0" Diameter (100218)
- Bracket Mains Input Plate 3.5" Diameter (100219)
- Temperature Sensor SCR (100268)
- Economizer Flange (100450-1)
- Cover Kit – Standard (100107)
- Screws for Covers (100252)
- End Bell Assembly (100324, 100324-2)
- PWM Module (100372)
- 342 TO 613 Inverter Conversion Kit (100521)

Some of the impacted items/kits are shown below in Figure 1.

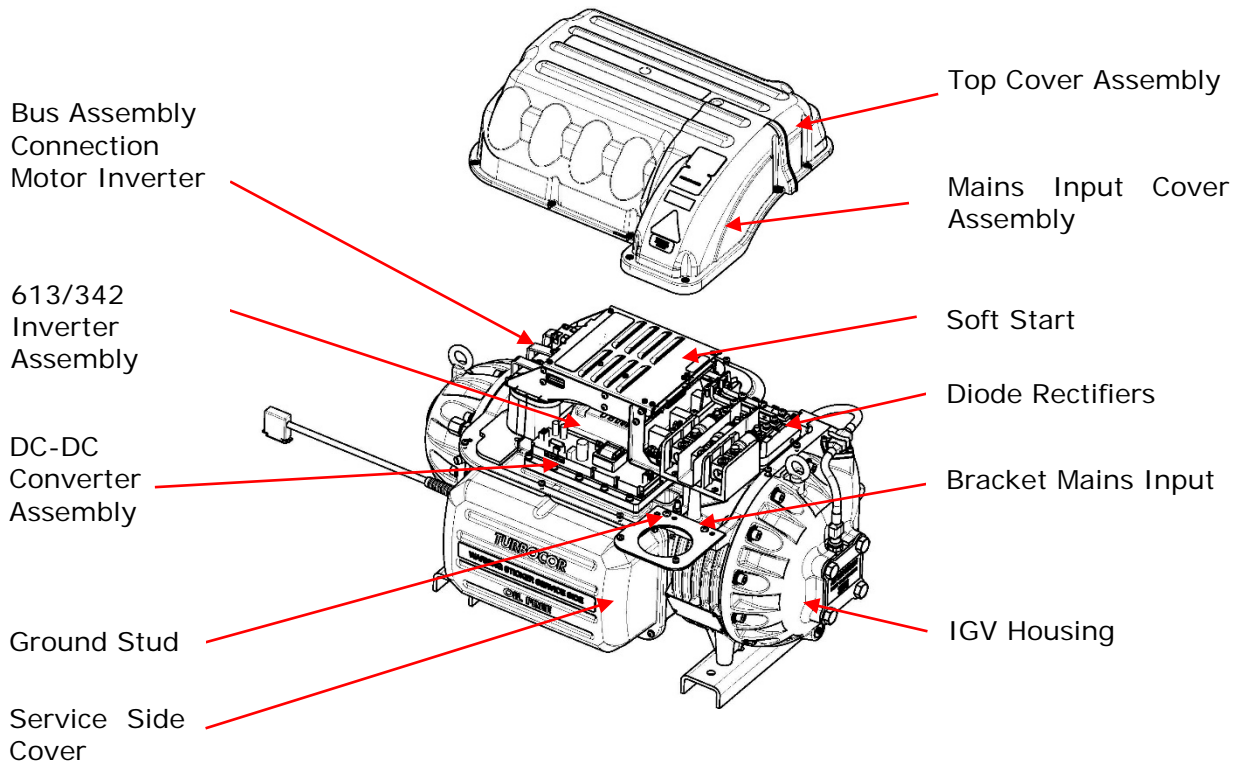

**Figure 1 – Impacted Items**

### Action Required

Customers are not required to take any action as a result of this change in regards to compressor ordering or ordering of spare parts. These changes will be phased into the production of the kits.

Some screws with a Philips head will be changed to either a Torx (T25/T45) or hex head. However, there are no changes to the torque values of the impacted fasteners.

### Need Assistance

For further questions, please contact [product.support@danfoss.com](mailto:product.support@danfoss.com).